

→ Application

- visual identification of direction and speed of wind at airports and heliports

→ Accordance with

- ICAO Annex 14, Vol. 1, 5.1.1
- EASA CS-ADR-DSN.K.490
- FAA Specification AC 150/5345-27 C

→ Description/properties

- when air moves with the speed of at least 6 km/hour, the revolving system situated at the top part of the pole on bearing will turn in direction of this movement
- top hole of the wind sleeve takes in the air stream and the sleeve swings, at the wind speed of at least 28 km/hour the sleeve inflates and indicates thus visually wind direction and speed

Wind Cone

- it is made from the mixture cotton and synthetic material in accordance with the standard EN 10204-2.2
- when inflated by air it gets shape of truncated cone

Construction of shell

- it keeps the entry hole of the cone open even at absolute windlessness, it supports the cone and keeps it in the required shape at the distance of three eights of its total length
- structure made of Al tubes is designed in such a way that it prevents accumulation of water in the cone
- shell bearings are self-lubricating

Pole

- tiltable structure with support enables easy replacement or maintenance of the cone, shell or lighting system and obstruction lights
- top part of the pole contains revolving fitting enabling rotation of the shell with the cone
- surface treatment by powder coating colour RAL 1021 (Yellow)

Lighting

- light reflectors assure that each point of the longitudinal axis of the sleeve top part in inflated state is lit by intensity of at least 10 cd
- power supply is lead inside the supporting structure from the terminal box situated independently next to the pole



- pole can be equipped with low intensity obstruction light mounted on the top of the pole (not shielded from the top view by any other component of the wind indicator)

→ Mechanical parameters

- height (without illumination) 6 500 mm
- height (with illumination) 6 750 mm
- total weight ~90 kg
- dimensions of wind sleeve (version heliport)
 - length 2,5 m
 - diameter 0,6 m
- dimensions of wind sleeve (version airport)
 - length 3,75 m
 - diameter 0,9 m
- resistance to wind up to 140 km/h
- working temperature ± 55 °C
- cone excludes accumulation of water
- minimum strength of fabric 667 N
- indication of wind direction by turning of wind sleeve with accuracy of $\pm 5^\circ$ at wind speed > 6 km/h
- wind cone fully inflated at wind speed > 28 km/h

→ Electrical parameters (illuminated variant)

- IP 54
- insulation resistance min 2 M Ω
- total power input 700 VA $\pm 10\%$ (halogen)
- total power input < 120 VA $\pm 10\%$ (LED)
- rated voltage 230 V / 50 Hz or 6,6 A airport series supply

chapter:

7.4

TWI

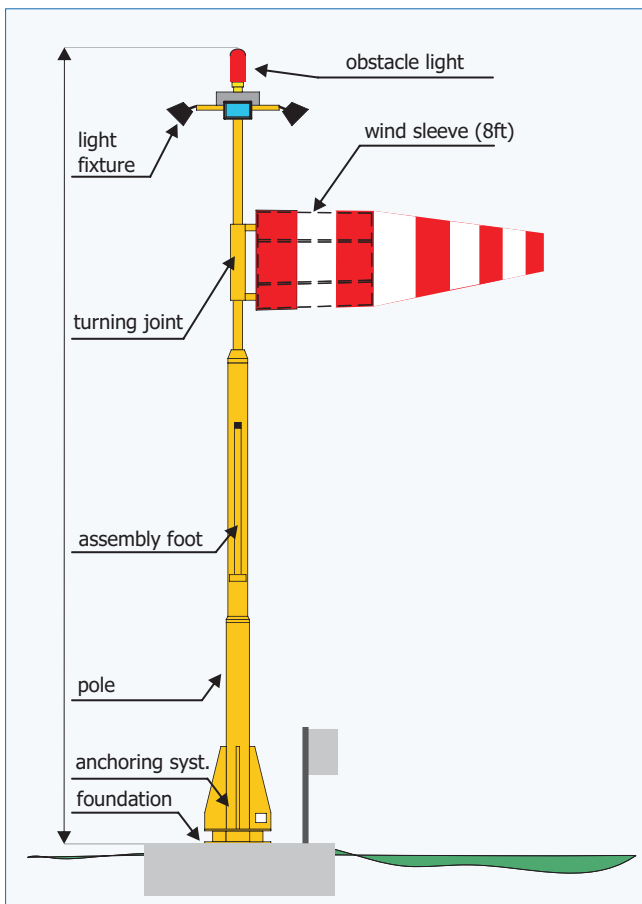

➔ Fixing to concrete foundation

- two steel plates inter-connected by a steel pin enabling tilting of the pole
- dimensions of the basis 300×300 mm
- fixation to the concrete foundation by four M16 threads

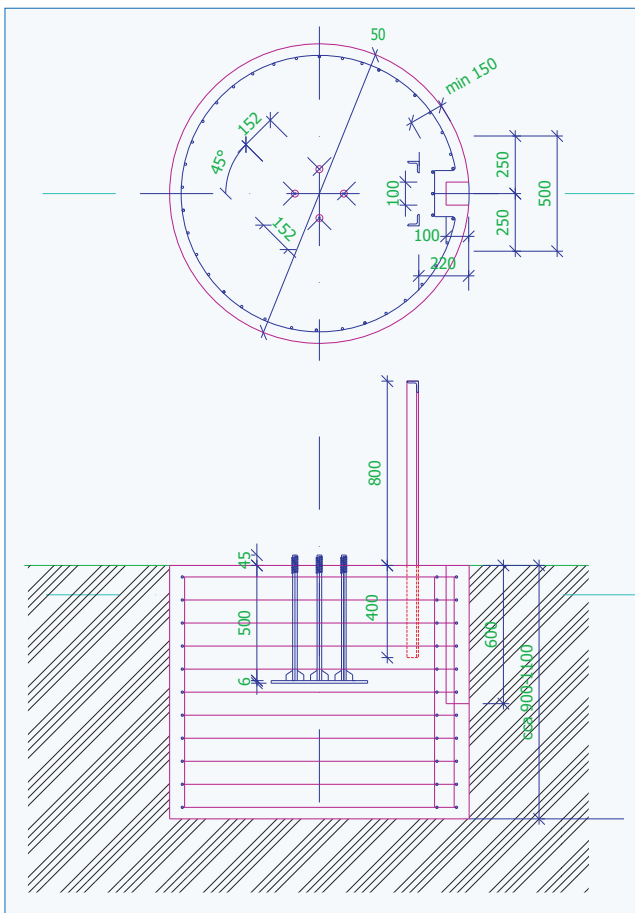

ORDERING CODES

TWI 10. X. X. X. X

Execution

- A=Airport version
- AC=Airport version (frangible pole)
- H=Helicopter version
- HC=Helicopter version (frangible pole)

Lighting

- 0=non-illuminated wind cone
- 1=non-illuminated wind cone + obstruction light
- 2=illuminated wind cone + obstruction light
- 3=LED illuminated wind cone + obstruction light, power supply 230 V AC
- 4=LED illuminated wind cone + obstruction light, power supply 6,6 /2,2 A or 230 V AC

Color of wind sleeve

- 0=orange / white sleeve (5 strips, orange strips at the end)

Termination

- 0=unconnected power cord (7×1,5)
- 1=terminal block without twilight sensor
- 2=terminal block with twilight sensor

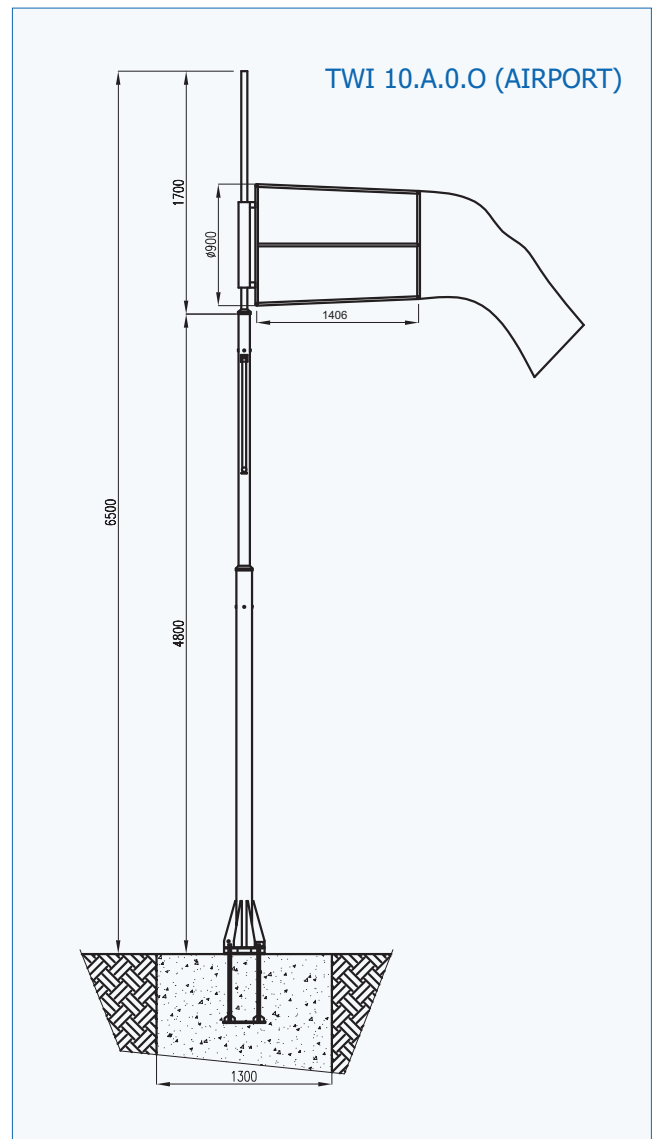
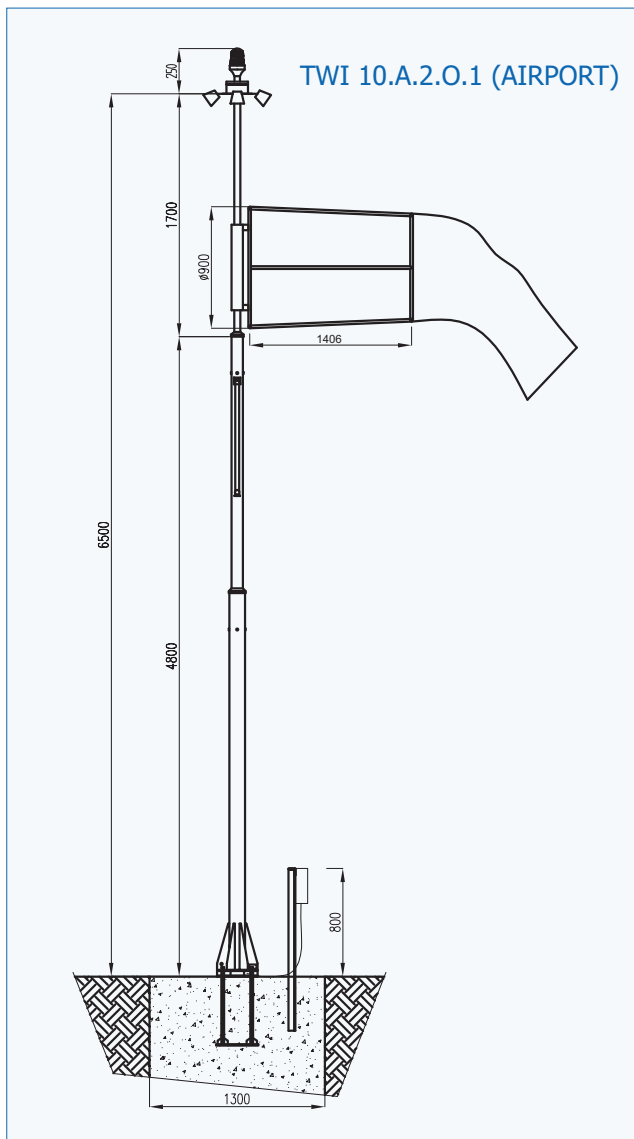

chapter:

7.4

TWI



TWI 10.H.2.O.1 (HELIPORT)

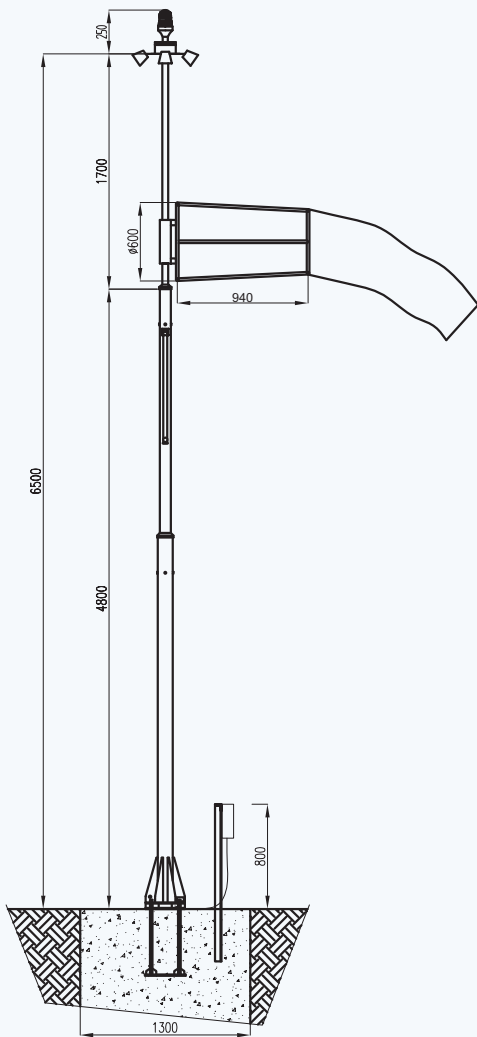

TWI 10.H.0.O (HELIPORT)

